

High Efficiency Commercial Gas Water Heater

USE & CARE MANUAL

WITH INSTALLATION INSTRUCTIONS FOR THE CONTRACTOR

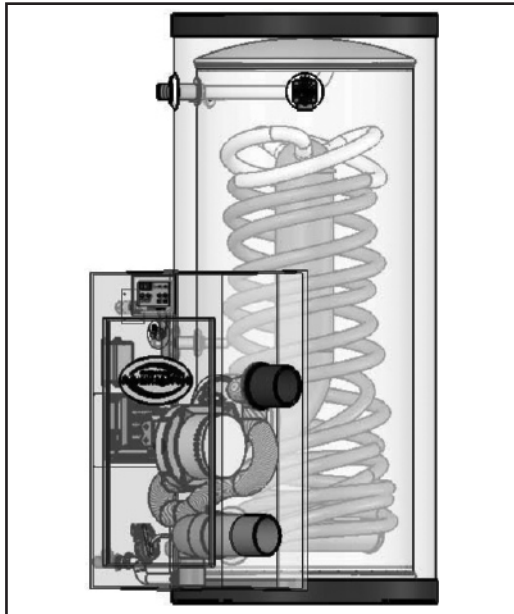

This Use & Care Manual covers the following model numbers:

HE55-100N	HE119-130N	HE55-199LP
HE55-130N	HE119-160N	HE80-130LP
HE55-160N	HE119-199N	HE80-160LP
HE55-199N	—————	HE80-199LP
HE80-130N	HE55-100LP	HE119-130LP
HE80-160N	HE55-130LP	HE119-160LP
HE80-199N	HE55-160LP	HE119-199LP



Recognize this symbol as an indication of important Safety Information!



Do Not Destroy this Manual. Please read carefully and keep in a safe place for Future Reference.

⚠ NOTICE

This water heater is designed for use in a commercial application. The installation and maintenance of it should be performed by qualified, licensed service personnel.

⚠ WARNING

Read and review this entire manual with special emphasis on the Venting and Operation Sections prior to any installation work.

⚠ CALIFORNIA PROPOSITION 65 WARNING

This product contains chemicals known to the State of California to cause cancer, birth defects and other reproductive harm.

⚠ WARNING

If the information in these instructions are not followed exactly, a fire or explosion may result causing property damage, personal injury or death.

⚠ FOR YOUR SAFETY!

- Do not store or use gasoline or other flammable vapors or liquids or other combustible materials in the vicinity of this or any other appliance. To do so may result in an explosion or fire
- WHAT TO DO IF YOU SMELL GAS
 - Do not try to light any appliance.
 - Do not touch any electrical switch; do not use any phone in your building.
 - Immediately call your gas supplier from a neighbor's phone. Follow the gas supplier's instructions.
- If you cannot reach your gas supplier, call the fire department.
- Do not return to your building until authorized by the gas supplier or fire department.
- Improper installation, adjustment, alteration, service or maintenance can cause injury, property damage or death. Refer to this manual. Installation and service must be performed by a qualified installer, service agency or gas supplier.

SPECIFICATIONS

RECOVERY CAPACITIES

Recovery in U.S. Gallons/Hr. (GPH) and Liters/Hr. (LPH) at Various Temperature Rises

MODEL NUMBER	INPUT (BTU/HR) NAT. & LP	THERMAL EFFICIENCY	UNITS	40°F (22.2°C)	50°F (27.8°C)	60°F (33.3°C)	70°F (38.9°C)	80°F (44.4°C)	90°F (50.0°C)	100°F (55.6°C)	110°F (61.1°C)	120°F (66.7°C)
HE55-100	100,000	95%	GPH	288	230	192	165	144	128	115	105	96
			LPH	1090	872	726	623	545	484	436	396	363
HE55-130 HE80-130 HE119-130	130,000	95%	GPH	374	299	249	214	187	166	150	136	125
			LPH	1417	1133	944	809	708	630	567	515	472
HE80-160 HE119-160	160,000	95%	GPH	461	368	307	263	230	205	184	167	154
			LPH	1744	1395	1162	996	872	775	697	634	581
HE80-199 HE119-199	199,000	95%	GPH	573	458	382	327	286	255	229	208	191
			LPH	2169	1735	1446	1239	1084	964	867	789	723

Recovery rating is based on thermal efficiencies obtained at Intertek Testing, an AGA certified laboratory.

BOOSTER MODELS Recovery in U.S. Gallons/Hr. (GPH) and Liters/Hr. (LPH)

MODEL NUMBER	INPUT (BTU/HR) NAT. & LP	THERMAL EFFICIENCY	UNITS	40°F (22.2°C)	50°F (27.8°C)	60°F (33.3°C)	70°F (38.9°C)	80°F (44.4°C)	90°F (50.0°C)	100°F (55.6°C)	110°F (61.1°C)	120°F (66.7°C)	130°F (72.2°C)	140°F (77.8°C)
HE55-160	160,000	95%	GPH	461	368	307	263	230	205	184	167	154	142	132
			LPH	1744	1395	1162	996	872	775	697	634	581	536	498
HE55-199	199,000	95%	GPH	573	458	382	327	286	255	229	208	191	176	164
			LPH	2169	1735	1446	1239	1084	964	867	789	723	667	620

All models exceed the minimum energy efficiency requirements of current ASHRAE 90.1 requirements.

MAXIMUM DELIVERY

In U.S. Gallons and Liters (Includes useable storage and recovery for indicated times)

MODEL NUMBER	GALLONS/ LITERS	MAX SETPOINT	INPUT (BTU/HR) NAT. & LP	TEMP. RISE	UNITS	5 MIN.	10 MIN.	15 MIN.	20 MIN.	30 MIN.	45 MIN.	1 HR.	2 HR.	3 HR.	MIN. TO RECOVER CONTENTS
HE55-100	55 208	160° 71°C	100,000	100°F	GAL.	48	58	67	77	96	125	154	269	388	29
				37.7°C	LTR.	182	219	255	291	364	473	582	1019	1455	
HE55-130	55 208	160° 71°C	130,000	100°F	GAL.	51	63	76	88	113	151	188	338	488	22
				37.7°C	LTR.	193	240	288	335	430	571	713	1281	1848	
HE80-130	80 303	160° 71°C	130,000	100°F	GAL.	68	81	93	106	131	168	206	355	505	32
				33.7°C	LTR.	259	306	354	401	495	637	779	1345	1912	
HE119-130	119 450	160° 71°C	130,000	100°F	GAL.	96	108	121	133	158	196	233	383	532	48
				33.7°C	LTR.	363	410	457	504	599	750	882	1449	2015	
HE55-160	55 208	180** 82°C	160,000	100°F	GAL.	54	69	85	100	131	177	223	407	591	18
				37.7°C	LTR.	204	262	320	379	495	670	844	1542	2241	
HE80-160	80 303	160° 71°C	160,000	100°F	GAL.	71	87	102	117	148	194	240	424	609	26
				37.7°C	LTR.	270	328	386	444	561	735	909	1607	2304	
HE119-160	119 450	160° 71°C	160,000	100°F	GAL.	99	114	129	145	175	221	268	452	636	39
				37.7°C	LTR.	373	432	490	548	664	838	1013	1710	2408	
HE55-199	55 208	180** 82°C	199,000	100°F	GAL.	57	77	96	115	153	210	268	497	726	14
				37.7°C	LTR.	218	291	363	435	580	797	1014	1883	2751	
HE80-199	80 303	160° 71°C	199,000	100°F	GAL.	75	94	113	132	171	228	285	514	743	21
				37.7°C	LTR.	284	357	429	501	646	863	1079	1947	2814	
HE119-199	119 450	160° 71°C	199,000	100°F	GAL.	102	121	141	160	198	255	312	542	771	31
				37.7°C	LTR.	338	460	532	604	749	966	1183	2050	2918	

All models have a maximum setpoint of 160°F/71°C with the exception of the HE55-160 and HE55-199 booster models. The HE55-160 and HE55-199 have a maximum setpoint of 180°F/82°C.

* NOTE: The 180°F/82°C models are shipped with all necessary components for an approved installation (see Booster Installation Kit for component list on Page 7.)

DIMENSIONAL INFORMATION

All dimensions shown in English and Metric

MODEL NUMBER	UNITS	HEIGHT	WIDTH	DEPTH	VENT	WATER CONNECTIONS INLET	WATER CONNECTIONS OUTLET	APPROX SHIPPING WT.
HE55-100	inches	52	23 1/2	32	2	1	1	175 lbs.
HE55-130	mm	1321	597	813	51	25	25	79 kgs
HE55-160	inches	52	23 1/2	32	3	1	1	175 lbs.
HE55-199	mm	1321	597	813	76	25	25	79 kgs
HE80-130	inches	72	23 1/2	32	3*	1-1/2	1-1/2	235 lbs.
HE80-160	mm	1854	597	813	76	38	38	106 kgs
HE80-199	mm	1854	597	813	76	38	38	106 kgs
HE119-130	inches	73	27	36	3*	1-1/2	1-1/2	405 lbs.
HE119-160	mm	1854	686	914	76	38	38	184 kgs
HE119-199	mm	1854	686	914	76	38	38	184 kgs

All models require a 120V power source.

* 130,000 Btu models are certified to be installed with 2" venting.

0" CLEARANCE TO COMBUSTIBLES ON ALL ADVANTAGEPLUS UNITS, HOWEVER, A 24" (61 cm) CONTROL PANEL SERVICE CLEARANCE IS RECOMMENDED.

TABLE OF CONTENTS

Part 1: General Safety Precautions	4-5
Part 2: Installation	6-10
A. Local Installation Regulations	6
B. Location	6
C. Temperature And Pressure Relief Valve	6
D. Expansion Tank	6
E. Domestic Water Connections	7
F. Special Instructions For Booster Installations	7
G. Lighting and Operating Instructions	8
H. Electrical Connection	9
I. Gas Connection	9-10
Part 3: Venting, Combustion Air & Condensate Removal	11-16
A. General	11
B. Approved Materials For Exhaust Vent And Intake Air Vent	11
C. Exhaust Vent And Intake Air Vent Pipe Location	11-13
D. Exhaust Vent And Intake Air Vent Sizing	14
E. Longer Vent Runs	14
F. Exhaust Vent And Intake Air Pipe Installation	14-15
G. Test Mode	15
H. Very Important Set-up Instructions	15
I. Concentric Vent	16
Part 4: Operation	17-19
A. Overall Appliance And Control Operation	17
B. Status Menu	17
C. Operating Instructions	18
D. Shutdown Procedure	18
E. Prevent Combustion Air Contamination	18
F. Corrosive Contaminants And Sources Products To Avoid	18
G. Condensate	19
Part 5: Components Of The AdvantagePlus	20-23
Service Parts, Wiring Diagram and How to Obtain Service	20-22
Most Common AdvantagePlus Installation Concerns	23
Part 6: Troubleshooting	24-25

PART 1: GENERAL SAFETY PRECAUTIONS

Be sure to read and understand the entire Use & Care Manual before attempting to install or operate this water heater. Pay particular attention to the following General Safety Precautions. Failure to follow these warnings could result in a fire or explosion, causing property damage, bodily injury or death. Should you have any problems understanding the instructions in this manual, STOP, and get help from a qualified installer or service technician or the gas supplier.

⚠ WARNING

Gasoline, as well as other flammable materials and liquids (adhesives, solvents, etc.), and the vapors they produce, are extremely dangerous. DO NOT handle, use or store gasoline or other flammable or combustible materials anywhere near or in the vicinity of a water heater. Be sure to read and follow the warning label pictured below and other labels on the water heater, as well as the warnings printed in this manual. Failure to do so can result in property damage, bodily injury, or death.

⚠ DANGER

Failure to install and properly vent the water heater to the outdoors as outlined in the Venting Section of this manual can result in unsafe operation of the water heater. To avoid the risk of fire, explosion, or asphyxiation from carbon monoxide, never operate this water heater unless it is properly vented and has an adequate air supply for proper operation. Be sure to inspect the vent system for proper installation at initial start-up and at least annually thereafter. Refer to maintenance section of this manual for more information regarding vent system inspections.

⚠ DANGER

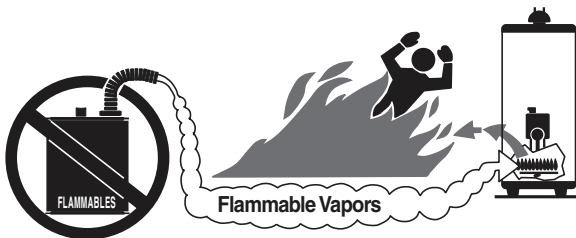

⚠ Vapors from flammable liquids will explode and catch fire causing death or severe burns.

Do not use or store flammable products such as gasoline, solvents or adhesives in the same room or area near the water heater.

Keep flammable products:

1. far away from heater,
2. in approved containers,
3. tightly closed and
4. out of children's reach.

Installation:
Do not install water heater where flammable products will be stored or used unless the main burner and pilot flames

Water heater has a main burner and pilot flame. The pilot flame:

1. which can come on at any time and
2. will ignite flammable vapors.

Vapors:

1. cannot be seen,
2. are heavier than air,
3. go a long way on the floor and
4. can be carried from other rooms to the pilot flame by air currents.

are at least 18" above the floor. This will reduce, but not eliminate, the risk of vapors being ignited by the main burner or pilot flame.

Read and follow water heater warnings and instructions. If owners manual is missing, contact the retailer or manufacturer.

⚠ DANGER

LIQUEFIED PETROLEUM MODELS

- Propane, or LP gas, must be used with great caution.
- It is heavier than air and will collect first in lower areas making it hard to detect at nose level.
- Make sure to look and smell for LP leaks before attempting to light appliance. Use a soapy solution to check all gas fittings and connections. Bubbling at a connection indicates a leak that must be corrected. When smelling to detect an LP leak, be sure to sniff near the floor.
- Gas detectors are recommended in LP applications and their installation should be in accordance with the manufacturer's recommendations and/or local laws, rules, regulations or customs.
- It is recommended that more than one method be used to detect leaks in LP applications.

IF LP GAS IS PRESENT OR SUSPECTED:

- DO NOT attempt to find the cause yourself;
- DO NOT try to light any appliance;
- DO NOT touch any electrical switch;
- DO NOT use any phone in your building.
- Leave the house immediately and make sure your family and pets leave also.
- Leave the doors open for ventilation and contact the gas supplier, a qualified service agency or the fire department.
- Keep the area clear until the service call has been made, the leak is corrected, and a qualified agency has determined the area to be safe.

⚠ WARNING

Both LP and natural gas have an odorant added to help detection. Some people may not physically be able to smell or recognize this odorant. If unsure or unfamiliar about the smell associated with LP or natural gas, ask the gas supplier. Other conditions, such as "Odorant Fade", which causes the odorant to "fade", or diminish in intensity can also hide or camouflage a gas leak.

⚠ DANGER

Water heaters utilizing Liquefied Petroleum gas (LP) are different from natural gas models. A natural gas heater will not function safely on LP gas and vice versa. No attempt should ever be made to convert a heater from natural gas to LP gas. To avoid possible equipment damage, personal injury or fire: DO NOT connect this water heater to a fuel type not in accordance with unit rating plate. Propane gas for propane units. Natural gas for natural gas units. These units are not certified for any other type fuel.

PART 1: GENERAL SAFETY PRECAUTIONS cont'd

⚠ WARNING

LP appliances should not be installed below-grade (for example, in a basement) if such installation is prohibited by federal, state and/or local laws, rules, regulations, or customs.

To meet commercial water use needs, the thermostat on this water heater is adjustable up to 160°F (71°C) (Booster models have a maximum setpoint of 180°F [82°C]). However, water temperatures over 125°F (52°C) can cause severe burns instantly or death from scalds. This is the preferred starting point for setting the controls for supplying general purpose hot water.

Safety and energy conservation are factors to be considered when setting the water temperature on the thermostat. The most energy efficient operation will result when the temperature setting is the lowest that satisfies the needs consistent with the application.

Maximum water temperatures occur just after burner has shut off. To find temperature of the water being delivered, turn on a hot water faucet and place a thermometer in the hot water stream and read the thermometer.

The following chart details the relationship of water temperature and time with regard to scald injury and may be used as a guide in determining the safest water temperature for your applications.

TIME / TEMPERATURE RELATIONSHIPS IN SCALDS

Temperature	Time to Produce Serious Burn
120°F (49°C)	More than 5 minutes
125°F (52°C)	1½ to 2 minutes
130°F (54°C)	About 30 seconds
135°F (57°C)	About 10 seconds
140°F (60°C)	Less than 5 seconds
145°F (63°C)	Less than 3 seconds
150°F (66°C)	About 1½ seconds
155°F (68°C)	About 1 second

Table courtesy of Shriners Burn Institute

The temperature of the water in the heater can be regulated by setting the temperature on the electronic thermostat. To comply with safety regulations, the thermostat was set at its lowest setting before the water heater was shipped from the factory. See the section titled SET POINT ADJUSTMENT PROCEDURE to set the electronic thermostat.

⚠ DANGER

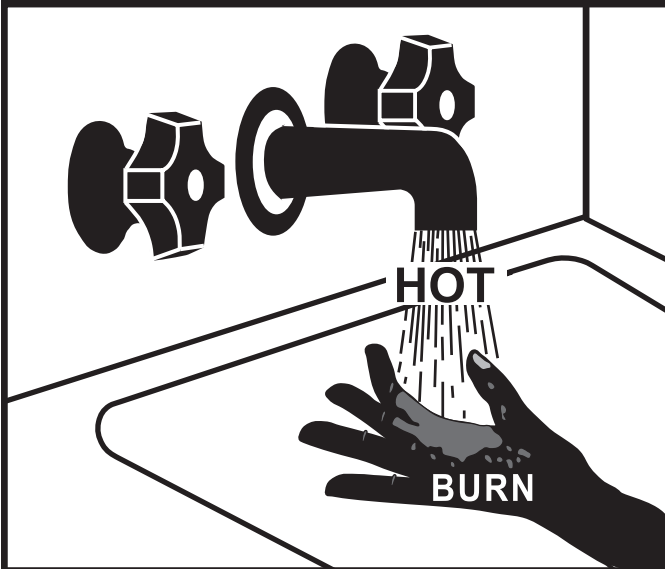

Water temperature over 125°F can cause severe burns instantly or death from scalds.

Children, disabled and elderly are at highest risk of being scalded.

See instruction manual before setting temperature at water heater.

Feel water before bathing or showering.

Temperature limiting valves are available, see manual.

⚠ DANGER

There is a Hot Water SCALD Potential if the thermostat is set too high.

NOTE: When this water heater is supplying general purpose hot water requirements for use by individuals, a thermostatically controlled mixing valve for reducing point of use water temperatures is recommended to reduce the risk of scald injury. Contact a licensed plumber or the local plumbing authority for further information.

PART 2: INSTALLATION

⚠ WARNING

Read and review this entire manual with special emphasis on the Venting Sections and Operation Sections prior to any installation work.

A. LOCAL INSTALLATION REGULATIONS

This water heater must be installed in accordance with these instructions, local codes, utility company requirements, and/or in the absence of local codes, the latest edition of the National Fuel Gas Code ANSI Z223.1 in the United States or CAN/CSA B149.1 installation code in Canada.

The water heater must be located or protected so it is not subject to physical damage, for example, by moving objects, area flooding, etc.

⚠ CAUTION

The water heater should not be located in an area where leakage of the tank or connections will result in damage to the area adjacent to it or to lower floors of the structure. When such areas cannot be avoided, it is recommended that a suitable catch pan, adequately drained, be installed under the water heater.

NOTE: Auxiliary catch pan installation MUST conform to the applicable local codes

B. LOCATION

Choose a location for your water heater centralized to the piping system, along with consideration to vent pipe length. As the length of vent pipe increases, the firing rate of the appliance decreases. You must also locate the AdvantagePlus where it will not be exposed to below freezing temperatures. Additionally, you will need to place the water heater so that the controls, drain, inlet/outlet, and gas valve are easily accessed. This appliance must not be installed outdoors, as it is certified as an indoor appliance, and must be kept vertical and on a level surface. Also, care must be exercised when choosing the location of this appliance where leakage from the relief valve, leakage from related piping, or leakage from the tank or connections, will not result in damage to the surrounding areas or to the lower floors of the building. **A water heater should always be located in an area with a floor drain or installed in an adequately drained catch pan suitable for water heaters.** Proper clearance must be provided around the AdvantagePlus as follows: Sides, bottom, top, and back are 0" (zero clearance). Front of the appliance needs 24" (61 cm) service clearance minimum. This front service may be achieved by a non-rated or combustible door or access panel; providing the 24" (61 cm) service clearance is achieved when the door is opened or panel is

removed. **This water heater must not be located near flammable liquids such as gasoline, adhesives, solvents, paint thinners, butane, liquefied propane, etc. as the controls of this appliance could ignite those vapors, causing an explosion.**

C. TEMPERATURE AND PRESSURE RELIEF VALVE

A new combination temperature and pressure relief valve, complying with the Standard for Relief Valves and Automatic Gas Shutoff Devices for Hot Water Supply Systems, ANSI Z21.22 or Standard CSA 4.4, must be installed in the opening provided on the water heater at the time of installation. No valve is to be placed between the relief valve and the water heater. For circulating tank installation, the separate storage tank(s) must have similar protection. The pressure rating of the relief valve must not exceed the maximum working pressure as marked on the front of the water heater. The Btu/h rating of the relief valve must equal or exceed the Btu/h input of the water heater as noted on its rating plate. Connect the outlet of the relief valve to a suitable open drain. The discharge line must pitch downward from the valve to allow complete draining (by gravity) of the relief valve and discharge line, and must be no smaller than the outlet of the relief valve. The end of the discharge line should not be threaded or concealed and should be protected from freezing. No valve of any type, restriction or reducer coupling should be installed in the discharge line. In the U.S., local codes shall govern the installation of relief valves. In Canada, use CAN/CSA B149.1.

D. EXPANSION TANK

A potable water expansion tank may be required to offset the water expansion as the water is heated. In most city plumbing systems, the water meter has a no return or back flow device built into the system to prevent back flowing of water back into city mains. Back flow preventers may be found on all incoming water supplies. Under these circumstances, you will need a hot water expansion tank listed for potable water use. The expansion tank should be located on the cold inlet piping close to the water heater. **The expansion tank must be suitable for potable water.**

⚠ WARNING

The manufacturer's warranty does not cover any damage or defect caused by installation or attachment or use of any special attachments such as energy saving devices (other than those authorized by the manufacturer) into, onto, or in conjunction with the water heater. The use of such unauthorized devices may shorten the life of the water heater and may endanger life and property. The manufacturer disclaims any responsibility for such loss or injury resulting from the use of such unauthorized devices.

E. DOMESTIC WATER CONNECTIONS

The water connections must be installed in accordance with all national and local plumbing codes, or any prevailing standard. **NEVER USE DIELECTRIC UNIONS OR GALVANIZED STEEL FITTINGS ON ADVANTAGEPLUS CONNECTIONS.** The inlet and outlet connections are 1" on the 55 gallon models and 1-1/2" on the 80 and 119 gallon models. On the cold inlet, install a 1" brass tee on the 55 gallon models, or a 1-1/2" brass tee on the 80 and 119 gallon models. On the run of the 1" brass tee install, with pipe sealant, compound a 1" brass drain cock or it's equivalent (*not supplied*). Into the branch of the 1" or 1-1/2" brass tee install a copper male adapter to match with the copper plumbing system. For convenience, you may install a shut off valve and a union in the cold inlet piping to ease servicing in the future. If there is a back flow preventer, or any type of a check valve in the system, then you must install an additional tee for a suitable potable thermal expansion tank. (See section on Expansion Tank.) In the hot outlet connection, (top left), install a suitable adapter to match the copper tubing of the plumbing system. A thermal trap or heat trap loop may be installed here to provide additional energy savings and prevent thermal siphoning of domestic hot water. If required, a domestic hot water tempering/anti-scald valve should be installed into the hot water line to prevent the maximum outlet water temperature from exceeding 125°F (52°C) to prevent scald injury.

F. SPECIAL INSTRUCTIONS FOR BOOSTER INSTALLATIONS

All booster heaters are supplied with the "Booster Installation" kit. In order to maintain proper temperature, this kit must be correctly installed. The Booster kit contains the following list of parts:

- #01 - Nibco Tee - 1"x 1"x 1/2" (2 pcs.)
- #02 - Female Adapter - 1" (2 pcs.)
- #03 - Dial Thermometer (2 pcs.)
- #04 - Expansion Tank - 4-1/2 Gal.
- #05 - Grundfos 3 Speed Pump w/ Check Valve
- #06 - Nibco 1.2" x 12" Fitting Air Chamber
- #07 - Vacuum Relief Valve
- #08 - Pressure Gauge - 0 - 200 PSI
- #09 - Nibco Tee 712R - 1"x 1" x 3/4" (2 pcs.)
- #10 - Nibco Tee 714RR - 1"x 1/2"x 1"
- #11 - Nibco Tee - 1"x 1/2"x 1" Copper
- #12 - Reducing Coupling
- #13 - Pressure Reducing Valve
- #14 - Nibco Male Adapter - 1"

See the following drawing for a typical "Booster" installation. Please note that those items marked with an asterisk in the drawing are not included with the Booster kit, but are items that should be installed in a typical dishwasher package.

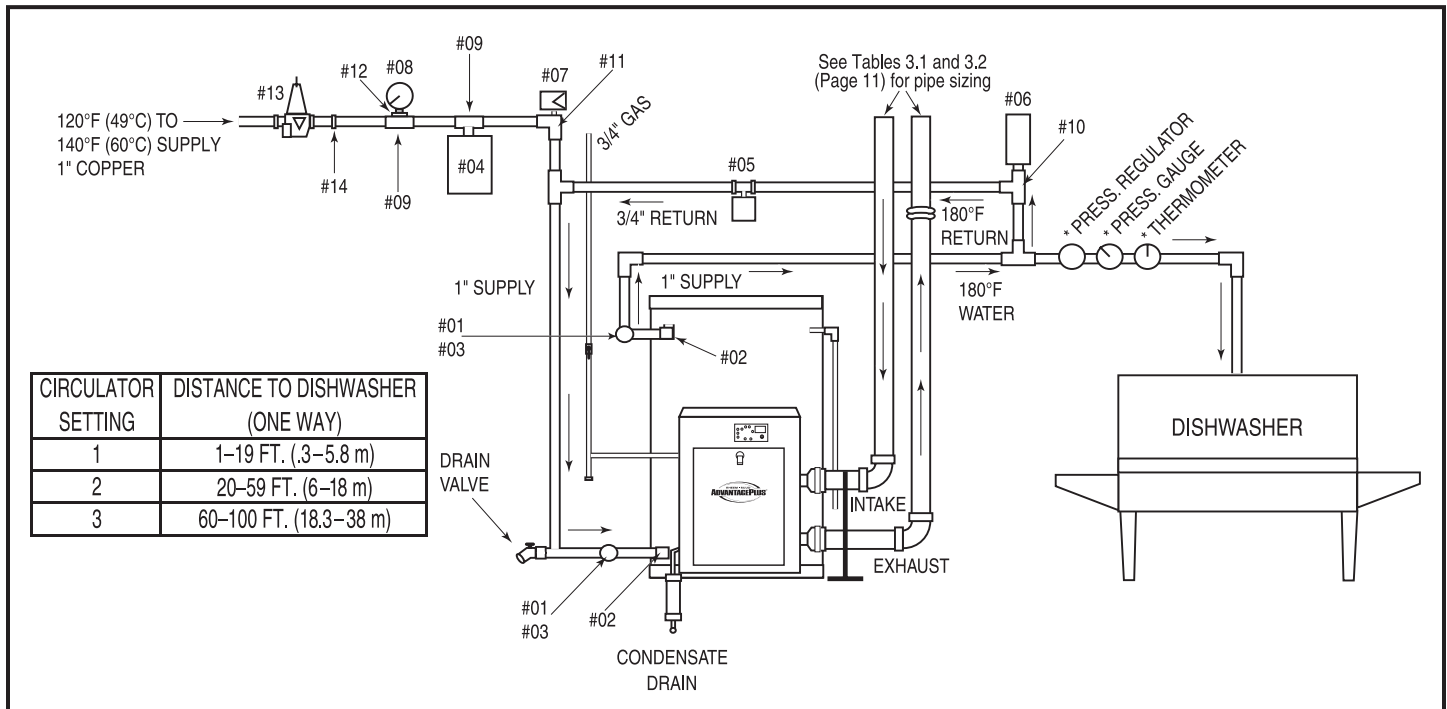

The booster heater is equipped with a circulating pump to provide the minimum water flow in the booster and maintain a uniform water temperature in the tank. Depending on the physical distance from the booster to the dishwasher, and the length of time between washes, it may be necessary to run an empty rack to purge the supply line of water that has cooled below 180°F (82°C). For this reason it is best to locate the booster as close as possible to the dishwasher. The circulator is equipped with three speeds to increase flow rate and reduce

heat loss. Reference the "Distance" chart to determine the appropriate circulator speed setting.

All piping should be installed with suitable pipe insulation to avoid temperature loss on the re-circulation line. A minimum of 1" thick pipe insulation is recommended. **Under no circumstances** should the the booster be installed without a circulating pump.

G. LIGHTING AND OPERATING INSTRUCTIONS

⚠ WARNING

If the information in this manual is not followed exactly, a fire or explosion may result causing property damage, personal injury or loss of life.

Do not store or use gasoline or other flammable vapors and liquids in the vicinity of this or any other appliance.

WHAT TO DO IF YOU SMELL GAS

- Do not try to light any appliance.
- Do not touch any electrical switch: do not use any phone in your building.
- Immediately call your gas supplier from a neighbor's phone. Follow the gas supplier's instructions.
- If you cannot reach your gas supplier, call the fire department. Installation and service must be performed by a qualified installer, service agency or the gas supplier.

FOR YOUR SAFETY READ BEFORE OPERATING

WARNING: If you do not follow these instructions exactly, a fire or explosion may result, causing property damage, personal injury or loss of life.

A. This appliance does not have a pilot. It is equipped with an ignition device which automatically lights the burner. Do not try to light the burner by hand.

B. BEFORE OPERATING smell all around the appliance area for gas. Be sure to smell next to the floor because some gas is heavier than air and will settle on the floor.

WHAT TO DO IF YOU SMELL GAS

- Do not try to light any appliance
- Do not touch any electric switch; do not use any phone in your building
- Immediately call your gas supplier from a neighbor's phone. Follow the gas suppliers' instructions.

• If you cannot reach your gas supplier, call the fire department.

C. Use only your hand to turn the gas control knob. Never use tools. If the handle will not turn by hand, don't try to repair it, call a qualified service technician. Force or attempted repair may result in a fire or explosion.

D. Do not use this appliance if any part has been under water. Immediately call a qualified service technician to inspect the appliance and to replace any part of the control system and any gas control which has been under water.

OPERATING INSTRUCTIONS

1. STOP! Read the safety information above.
2. Set the thermostat to lowest setting.
3. Turn off all electric power to the appliance.
4. This appliance is equipped with an ignition device which automatically lights the burner. Do not try to light the burner by hand.
5. Remove front cover.
6. Turn gas shutoff valve to "off". Handle will be across the piping, do not force.
7. Wait five (5) minutes to clear out any gas. If you then smell gas, STOP! Follow "B" in the safety information above on this label. If you don't smell gas, go to next step.
8. Turn gas shutoff valve to "on". Handle will be in line with piping.
9. Install Front Cover.
10. Turn on all electric power to appliance.
11. Set thermostat to desired setting.
12. If the appliance will not operate, follow the instructions "To Turn Off Gas To Appliance" and call your service technician or gas supplier.

**GAS VALVE
ON**

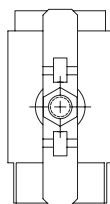

**GAS VALVE
OFF**

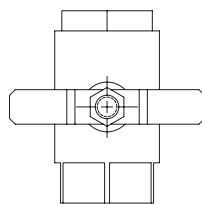

TO TURN OFF GAS TO APPLIANCE

1. Set the thermostat to lowest setting.
2. Turn off all electric power to the appliance if service is to be performed.
3. Remove Front Cover.
4. Turn gas shutoff valve to "off". Handle will be across the piping. Do not force.
5. Install Front Cover.

⚠ WARNING

Tank MUST be full of water before power is turned on. Heat exchanger coil WILL BE DAMAGED if energized even for a short time while the tank is dry. The water heater's warranty does not cover damage or failure resulting from operation with an empty or partially empty tank. (Reference is made to the limited warranty for complete terms and conditions)

H. ELECTRICAL CONNECTION

The electrical connection for the AdvantagePlus is on the left side of the combustion shroud. There is a 1/2" knock-out location for electrical connection. All electrical wiring must be performed by a qualified licensed electrician, and in accordance with National Electrical Code and Canadian Electrical Code, or to the applicable local codes and standards. The electrical requirements are for standard 120 volts, 60 Hz., 10 amp service. It is recommended that an electrical disconnect switch be placed near the water heater, and that the connection to the AdvantagePlus be made using 3/8" extra-flex, or 3/8" greenfield (or equivalent). **This unit must be wired with #14 AWG, and fused for no more than 15 amps. It is of extreme importance that this unit be properly grounded and be connected with proper polarity!** Ground the water heater by connecting the green wire in the electrical access compartment directly to the main building ground system. **It is very important that the building system ground is inspected by a qualified electrician prior to making this connection.** Once all connections have been made, the electrical access may be closed. It is very important that the electrical power is not turned on until gas and venting connections are completed and the tank is full of water.

I. GAS CONNECTION

Refer to the below table to size the supply piping to minimize pressure drop between meter or regulator and unit. In Canada, use table found in CAN/CSA B149.1

Maximum Capacity of Pipe in Cubic Feet of Gas per Hour for Gas Pressures of 0.5 psi or Less and a Pressure Drop of 0.3 Inch water Column

Gas Table

(Nominal Iron Pipe Size (inches))	Internal Diameter (inches)	Length of Pipe (Feet)							
		10	20	30	40	50	60	70	
3/4	.824	278	190	152	130	115	105	96	} BTU'S PER HOUR x1,000
1	1.049	520	350	285	245	215	195	180	
1 1/4	1.380	1,050	730	590	500	440	400	370	
1 1/2	1.610	1,600	1,100	890	760	670	610	560	

(Nominal Iron Pipe Size (inches))	Internal Diameter (inches)	Length of Pipe (Feet)							
		80	90	100	125	150	175	200	
3/4	.824	90	84	79	72	64	59	55	} BTU'S PER HOUR x1,000
1	1.049	170	160	150	130	120	110	100	
1 1/4	1.380	350	320	305	275	250	225	210	
1 1/2	1.610	530	490	460	410	380	350	320	

It is recommended that a soapy solution be used to detect leaks. Bubbles will appear on the pipe to indicate a leak is present. The gas piping must be sized for the proper flow and length of pipe, to avoid excessive pressure drop. Both the gas meter and the gas regulator must be properly sized for the total gas load. **If you experience a pressure drop greater than 1" WC, the meter, regulator or gas line is undersized or in need of service.** You can attach a manometer to the incoming gas drip leg, by removing the cap and installing the manometer. The gas pressure must remain between 3.5" WC and 14" WC during stand-by (static) mode and while in operating (dynamic) mode at full output. **If an in-line regulator is used, it must be a minimum of 10 feet from the AdvantagePlus. It is very important that the gas line is properly purged by the installer, gas supplier or utility. Failure to properly purge the lines or improper line sizing, will result in ignition failure.** This problem is especially noticeable in NEW LP installations and also in empty tank situations. This can also occur when a utility company shuts off service to an area to provide maintenance to their lines. The gas valve must not be replaced with a conventional gas valve under any circumstances. As an additional safety feature in the AdvantagePlus water heater, the gas valve in this appliance has a flanged connection to the swirl plate and blower.

Gas supply shall not exceed a maximum inlet pressure of 14" water column (350 mm), 1/2 pound pressure (3.4 kPa), between 3.5" WC and 14" WC (natural and propane). The entire piping system, gas meter, and regulator must be sized properly to prevent a pressure drop greater than 0.5" of water column as stated in the National Fuel Gas Code. In Canada use CAN/CSA B149.1. Gas pressure information is listed on the rating plate. **It is very important that you are connected only to the type of gas noted on the rating plate; "LP" or propane gas or "Nat" natural gas.** All gas connections must be approved by the local gas supplier or utility in addition to the governing authority prior to turning the gas supply on. The nipple provided for the inlet gas connection is 1/2", and it is mandatory that a 3/4" to 1/2" reducing bushing (provided) is used, threaded into the branch of a 3/4" tee, and a drip leg fabricated, as per the National Fuel Gas Code and in Canada refer to CAN/CSA B149.1.

You must ensure that the entire gas line to the reducing bushing connection at the AdvantagePlus is no smaller than 3/4".

⚠ CAUTION

THE USE OF FLEXIBLE GAS CONNECTORS IS NOT RECOMMENDED. HOWEVER, IF USED, IT IS IMPERATIVE THAT THEY ARE SIZED CORRECTLY. FLEXIBLE GAS CONNECTORS MUST HAVE A MINIMUM ID OF 3/4". A MINIMUM 3/4" ID MUST BE MAINTAINED TO AVOID RESTRICTION OF GAS FLOW! NEVER REDUCE THE GAS SUPPLY LINE BELOW 3/4"! In Canada, refer to CAN/CSA B149.1 for approved connections.

Once all the inspections have been performed, the piping system must be leak tested. If the leak test pressure is higher than the maximum permissible inlet pressure, you must isolate the AdvantagePlus from the gas line before testing. In order to do this, you must disconnect the union and cap the inlet gas line. *In the event the gas valve is exposed to a pressure greater than 1/2 PSI, 14" water column, the gas valve must be replaced.*

Failure to follow all precautions could result in fire, explosion or death! It is recommended that a soapy solution be used to detect leaks. Bubbles will appear and indicate a leak is present. The gas piping must be sized for the proper flow and length of pipe to avoid unacceptable pressure drop. Both the gas meter and the gas regulator must be properly sized for the total gas load. If you experience a pressure drop greater than 1" W.C., the meter or regulator or gas line may be undersized or in need of service. Shown below is the inlet pressure tap to monitor the gas pressure. A small screw driver can be used to open needle valve. Slide the gas meter hose to monitor gas pressure. The gas pressure must remain between 3.5" and 14" of water column during stand-by and unit running heat cycle. If an in-line regulator is used, it must

be a minimum of 10 feet from the AdvantagePlus. It is **very important that the gas line is properly purged by the installer, gas supplier or utility. Failure to properly purge the lines or improper line sizing, will result in ignition failure of the AdvantagePlus.** The gas valve is a special gas valve which has a Pressure Augmented Regulator feature, as well as negative outlet pressure. This valve must not be replaced with a conventional valve under any circumstances. Make sure valve is in the "OFF" position prior to turning gas supply on. As an additional safety feature, this valve has a left hand thread on the outlet end, and a special tamper resistant electrical connector.

⚠ WARNING

Never use open flame to test for gas leaks, as bodily injury or property damage could result.

⚠ WARNING

DO NOT exceed input shown on water heater rating label.

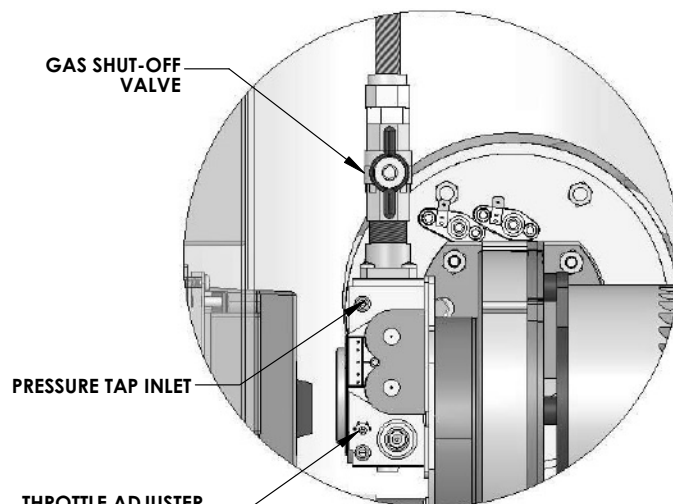

THROTTLE ADJUSTER

NOTE: If for any reason the throttle needs to be adjusted, it is very important that a "COMBUSTION ANALYZER" be used to ensure safe and proper operation. Turn the adjuster to the (+) to increase the gas supply or to the (-) to decrease the gas supply. This adjustment will affect CO/CO% levels. Make sure the levels correspond to the chart in combustion settings.

PART 3: VENTING, COMBUSTION AIR & CONDENSATE REMOVAL

⚠ WARNING

This vent system will operate with a positive pressure in the flue gas vent pipe. Do not connect vent connectors serving appliances vented by natural draft into any portion of mechanical draft systems operating under positive pressure. Follow the venting instructions below carefully. Failure to do so may result in severe personal injury, death, or substantial property damage.

A. GENERAL

1. Install the water heater venting system in accordance with these instructions and with the National Fuel Gas Code, ANSI Z223.1/NFPA 54, CAN/CGA B149.1, and/or applicable provisions of local building codes.
2. This water heater is a direct vent appliance and is listed as a Category IV appliance with Underwriters Laboratories, Inc. VENT AND INTAKE AIR VENT

B. APPROVED MATERIALS FOR EXHAUST VENT AND INTAKE AIR VENT

Table 3-1

APPROVED PLASTIC EXHAUST VENTING MATERIAL		
MATERIAL	STANDARDS FOR INSTALLATION IN:	
	UNITED STATES	CANADA
PVC SCHEDULE 40 / 80	ANSI /ASTM D1785	ULC-S636
PVC -DWV	ANSI /ASTM D2665	ULC-S636
CPVC SCHEDULE 40 / 80	ANSI /ASTM F441	ULC-S636
*Note: Cellular Foam Core Pipe can only be used on INTAKE piping.		

Table 3-2

APPROVED PLASTIC INTAKE VENTING MATERIAL	
MATERIAL	STANDARDS FOR INSTALLATION IN:
	UNITED STATES AND CANADA
PVC SCHEDULE 40 / 80	ANSI /ASTM D1785
CPVC SCHEDULE 40 / 80	ANSI /ASTM F441
PVC DWV	ANSI /ASTM D2665
PVC-CELLULAR FOAM CORE*	U.L. LISTED
*Note: Cellular Foam Core Pipe can only be used on INTAKE piping.	

Table 3-3

APPROVED PLASTIC CONDENSATE PIPING MATERIAL	
MATERIAL	STANDARDS FOR INSTALLATION IN:
	UNITED STATES AND CANADA
PVC SCHEDULE 40 / 80	ANSI /ASTM D1785

Table 3-4

APPROVED PIPE CEMENT AND PRIMER FOR PLASTIC PIPE		
MATERIAL	STANDARDS FOR INSTALLATION IN:	
	UNITED STATES	CANADA
CEMENT AND PRIMER		
CPVC	ANSI/ASTM F493	ULC-S636 approved primer and adhesive system, for ULC-S636 pipe and fittings
PVC	ANSI/ASTM D2564	

⚠ WARNING

Do not use Foam Core Pipe in any portion of the exhaust piping from this water heater. Use of Foam Core Pipe may result in severe personal injury, death, or substantial property damage.

C. EXHAUST VENT AND INTAKE AIR VENT PIPE LOCATION

1. Determine exhaust vent location:

⚠ WARNING

Both exhaust and intake air vents must exit from the same side of the building to assure correct appliance operation.

- a. The vent piping for this water heater is approved for zero clearance to combustible construction.
- b. See illustration within this section of clearances for location of exit terminals of direct-vent venting systems.
- c. This water heater vent system shall terminate at least 3 feet (0.9 m) above any forced air intake located within 10 ft (3 m). Note: this does not apply to the combustion air intake of this direct-vent appliance.
- d. Provide a minimum of 1 foot distance from any door, operable window, or gravity intake into any building.
- e. Provide a minimum of 1 foot clearance from the bottom of the exhaust above the expected snow accumulation level. Snow removal may be necessary to maintain clearance.
- f. Provide 4 feet horizontal clearance from electrical meters, gas meters, gas regulators, relief equipment, exhaust fans and inlets. In no case shall the exit terminal be above or below the aforementioned equipment unless the 4 foot horizontal distance is maintained.
- g. When adjacent to a public walkway, locate exit terminal at least 7 feet above grade.
- h. Do not locate the exhaust directly under roof overhangs to prevent icicles from forming.

- i. Provide 4 feet clearance from the inside corner of vertical walls, chimneys, etc., as well as horizontal corners created by roof overhangs.

2. Determine air intake vent location.

- a. Provide 1 foot clearance from the bottom of the intake air vent and the level of maximum snow accumulation. Snow removal may be necessary to maintain clearances.
- b. Do not locate intake air vent in a parking area where machinery may damage the pipe.

- c. When venting with a two pipe system, maximum distance between intake air vent and exhaust vent is 6 feet (1.8 m). Minimum distance between exhaust vent and intake air vent on single water heater is 8" (0.2 m) center-to-center. Minimum distance between exhaust vents and intake air vents on multiple water heaters is 8" (0.2 m) center-to-center.
- d. You must place support brackets on vent piping. The first bracket must be within 1 foot of the appliance and the balance at 4 foot intervals on the vent pipe.

Location of exit terminals of mechanical draft and direct-vent venting systems.

(Reference: National Fuel Gas Code ANSI Z223.1/NFPA 54 2002). In Canada, refer to CAN/CSA B149.1 for vent terminal location

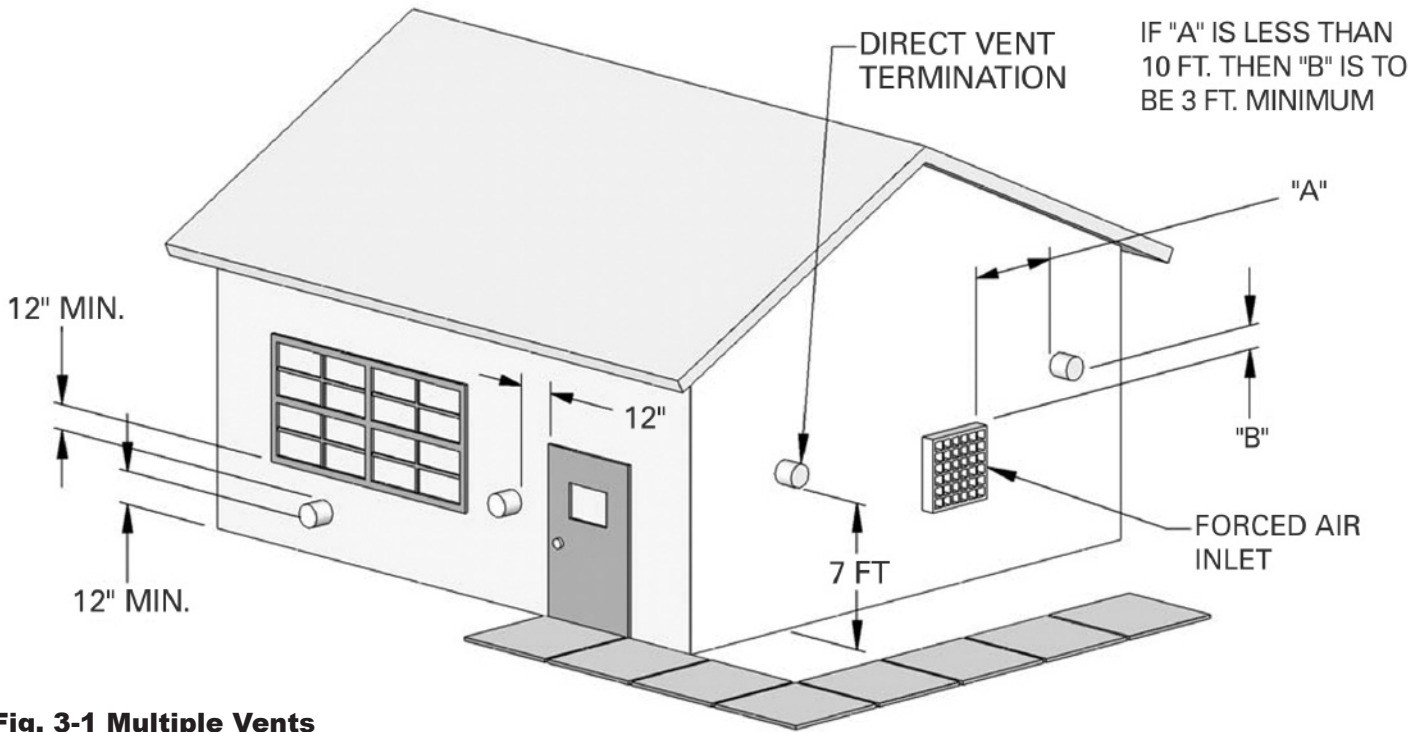

Fig. 3-1 Multiple Vents

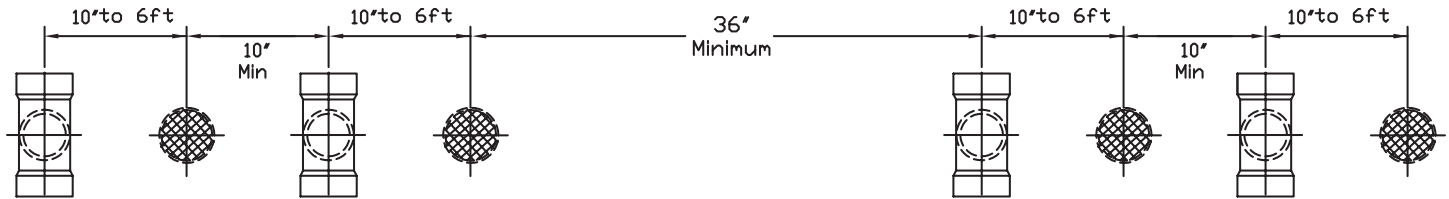

Fig. 3-2 Multiple Vent Spacing*

*Note: Exhaust must extend 1 foot. There should be no more than 2 vents and 2 intakes then a space of 36" to the next set of vents.
 *Note: There must be a minimum of 36" spacing between every 2 kit grouping.

Multiple Series Vents

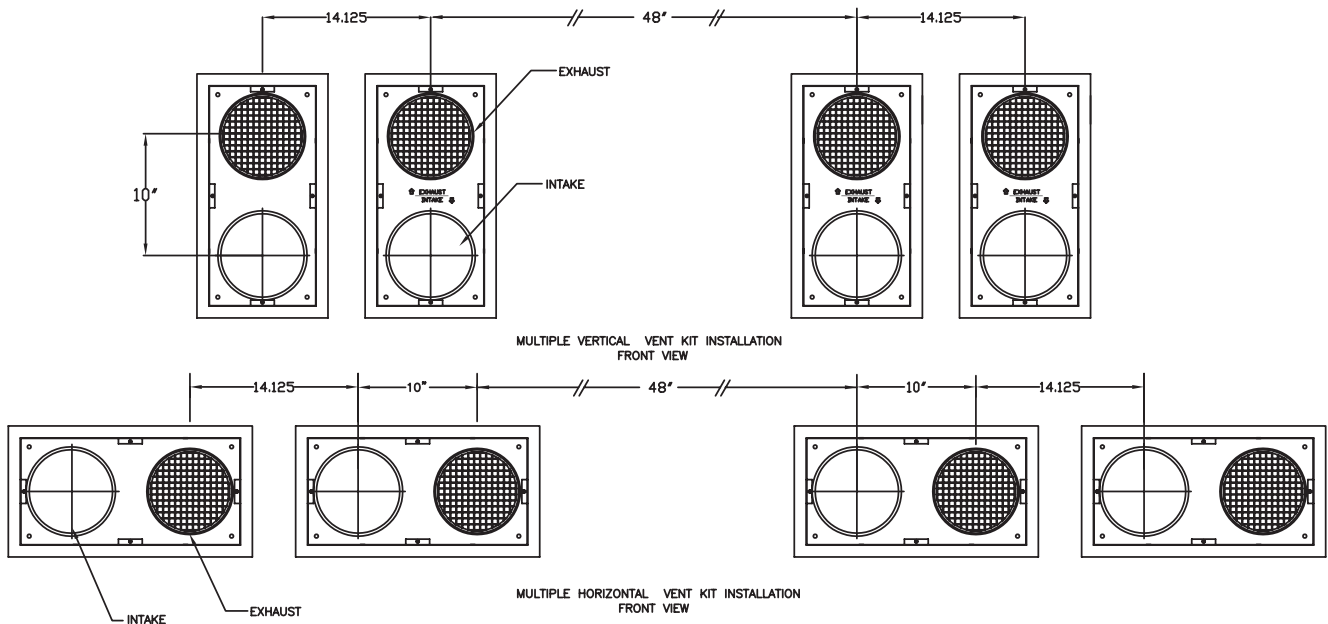

Fig. 3-3 Multiple Stainless Steel Horizontal Vent Kit Installation – Front View

D. EXHAUST VENT AND INTAKE AIR VENT SIZING

- The exhaust and intake vent size is 2" for the HE100 and HE130 and 3" for the HE199.
- The total combined equivalent length of exhaust vent and intake air pipe should not exceed 85 feet.
 - The equivalent length of elbows, tees, and other fittings are listed in the Friction Loss Table 3-5.

Table 3-5

FRICTION LOSS EQUIVALENT IN PIPING AND FITTINGS			
FITTINGS OR PIPING	EQUIVALENT FEET		
	2" (5 cm)	3" (7.6 cm)	4" (10 cm)
90 DEGREE ELBOW*	5' (1.5 m)	5' (1.5 m)	3' (.92 m)
45 DEGREE ELBOW	3' (.92 m)	3' (.92 m)	1' (.31 m)
COUPLING	0'	0'	0'
AIR INLET TEE	0'	0'	0'
STRAIGHT PIPE	1' (.31 m)	1' (.31 m)	1' (.31 m)
CONCENTRIC VENT KIT SP12161	3' (.92 m)	3' (.92 m)	N/A
V1000 3" VENT KIT SP12162	N/A	1' (.31 m)	1' (.31 m)

*Friction loss for long radius elbow is 1 foot less

- For example: If the exhaust vent has two 90° elbows and 10 feet of PVC pipe we will calculate:

$$\text{Exhaust Vent Pipe Equivalent Length} = (2 \times 5) + 10 = 20 \text{ feet} \\ (.61 \text{ m} \times 1.5 \text{ m}) + 3 \text{ m} = 6.1 \text{ m}$$

Further, if the intake air vent pipe has two 90° elbows, one 45° elbow and 10 feet of PVC pipe, the following calculation applies:

$$\text{Intake Air Vent Pipe Equivalent Length} = (2 \times 5) + 3 + 10 = 23 \text{ feet} \\ (.61 \text{ m} \times 1.5 \text{ m}) + .92 \text{ m} + 3 \text{ m} = 7 \text{ m}$$

Finally, if a concentric vent kit is used we find:

$$\text{Total Combined Equivalent Length} = 20 + 23 + 3 = 46 \text{ feet} \\ .61 \text{ m} + 7 \text{ m} + .92 \text{ m} = 14 \text{ m}$$

Therefore, the total combined equivalent length is 46 feet which is well below the maximum of 85 feet.

- The intake air vent pipe and the exhaust vent are intended to penetrate the same wall or roof of the building.
 - Effort should be made to keep a minimum difference in equivalent length between the intake air vent pipe and the exhaust vent.
- The minimum combined equivalent length is 16 equivalent feet.

E. LONGER VENT RUNS

- The maximum combined equivalent length can be extended by increasing the diameter of both exhaust vent and intake air vent pipe equally. However, the

transitions should begin a minimum of 15 equivalent feet from the water heater.

- The maximum equivalent length for the increased diameter vent pipes is 125 feet.
- Transitions should always be made in vertical sections of pipe to prevent the condensate from pooling in the vent pipe.

Table 3-6: Vent Run Transition

Vent Connection	Reducing Coupling	Vent Transition
2" (5 cm)	3" x 2" (7.6 cm x 5 cm)	3" (7.6 cm)
3" (7.6 cm)	4" x 3" (10 cm x 7.6 cm)	4" (10 cm)

- If the transition occurs at a distance greater than 15 equivalent feet from the water heater, the maximum equivalent length will be reduced. See Table 3-7.

Table 3-7: Vent Termination Kits

Transition Point (ft from water heater)	TEL of Standard 2" Vent Pipe (ft)	TEL of Oversized 2", 3" or 4" Vent Pipe (ft)	Maximum TEL of all Vent Pipe (ft)
15 (4.58m)	30 (9.1m)	95 (29m)	125 (38m)
20 (6m)	40 (12.2m)	77-1/2 (23.6m)	117-1/2 (35.9m)
25 (7.6m)	50 (15.2m)	60-1/2 (18.4m)	110-1/2 (33.7m)
30 (9.1m)	60 (18.2m)	43 (13.1m)	103 (31.4m)
35 (10.7m)	70 (21.3m)	26 (7.92m)	96 (29.2m)
40 (12.2m)	80 (24.3m)	8-1/2 (2.6m)	88-1/2 (27m)
None	85 (27m)	0	85 (26m)

TEL = Total Equivalent Length

F. EXHAUST VENT AND INTAKE AIR PIPE INSTALLATION

- Use only solid PVC or CPVC for exhaust vent pipe. FOAM CORE PIPING, as well as PVC and CPVC, can be used for the intake vent pipe. Refer to chart Section 3B, Page 11.
- Remove all burrs and debris from joints and fittings.
- All joints must be properly cleaned, primed, and cemented. Use only cement and primer approved for use with the pipe material. Cement must conform to ASTM D2564 for PVC and ASTM F493 for CPVC pipe.

⚠ WARNING

All joints of positive pressure vent systems must be sealed completely to prevent leakage of flue products into the living space.

- Horizontal lengths of exhaust vent must slope back towards the water heater not less than 1/4" per foot to allow condensate to drain from the vent pipe. If the exhaust pipe must be piped around an obstacle that results in the creation of a low point, condensate

will collect in this low point and form a blockage. This condensate must be drained away using a field-installed condensate drain assembly as shown. (See page 19)

5. All piping must be fully supported. Use pipe hangers at a minimum of 4 foot (1.2m) intervals to prevent sagging of the pipe where condensate may form.
6. Do not use the water heater to support any piping.
7. A screened straight coupling is provided with the water heater for use as an outside exhaust termination.

G. TEST MODE

This function is intended to simplify the gas valve adjustment if needed. See Fig. 1 Pg. 10 for gas valve adjustment location. Listed below are the recommended limits on each Water Heater and the Combustion Settings. Automatic modulation does not take place when the controller is in Test mode, only temperature limitation based on the AdvantagePlus set point. The user will be allowed to increase or decrease the fan speed by pressing in either the **S1/-** or **S2/+** keys.

To activate the Test mode simply press the **S2/+** and **S3/Program** key together for 1 second. Once activated, you will see in the display **Ser** and the actual fan speed. The measurement of the combustion levels should always be taken at the highest and lowest fan speed.

After 10 minutes, the Test mode stops automatically. To exit Test Mode press **S1/-** and **S2/+** key together for 1 second.

H. VERY IMPORTANT SET-UP INSTRUCTIONS!

IF YOU HAVE A COMBUSTION ANALYZER, THE FOLLOWING RATINGS WILL BE **VERY HELPFUL** IN SETTING UP YOUR ADVANTAGEPLUS:

COMBUSTION SETTINGS HIGH FIRING RATES AND LOW FIRING RATES ON ALL MODELS				
	Natural Gas		Propane LP	
	low	high	low	high
Carbon Monoxide (CO%)	0–10 ppm	0 ppm–20 ppm	0–10 ppm	0 ppm–20 ppm
Carbon Dioxide (CO2%)	8½% – 9½%	8½% – 9½%	9½% – 10½%	9½% – 10½%

FAN SPEEDS			
BTU	IGNITION	MIN	MAX
100,000	3000	2000	5400
130,000	3000	2000	6950
199,000	3000	2000	8500

I. CONCENTRIC VENT

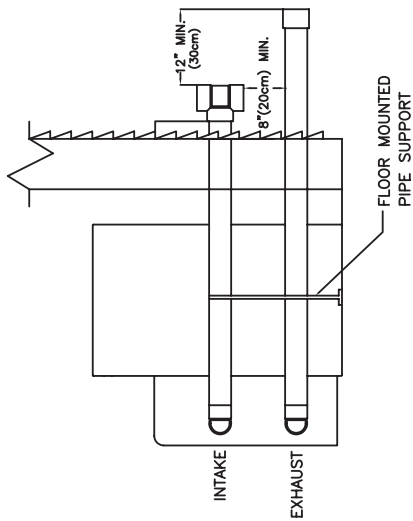

FIGURE 1
SIDE VENTING
SIDE VIEW

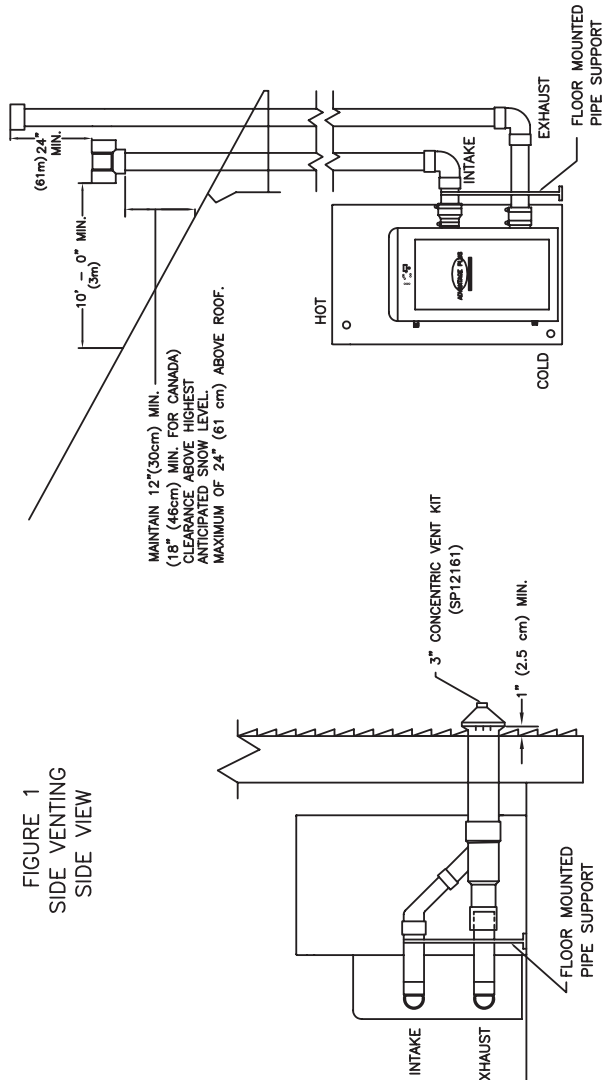

FIGURE 2
SIDE VENTING
SIDE VIEW

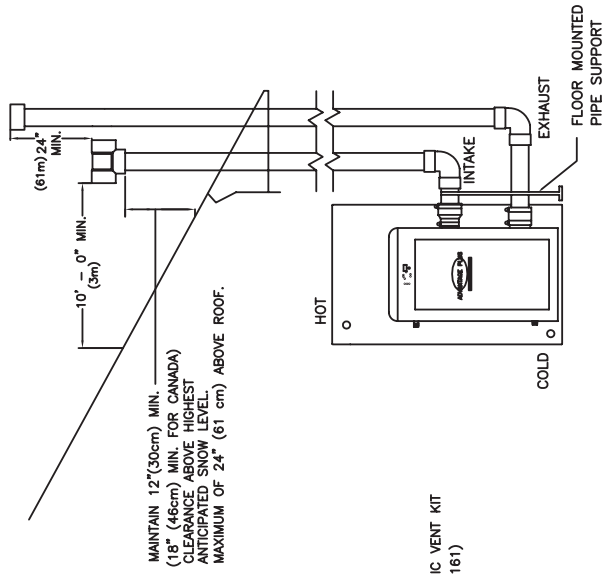

FIGURE 3
VERTICAL ROOF VENTING
FRONT VIEW

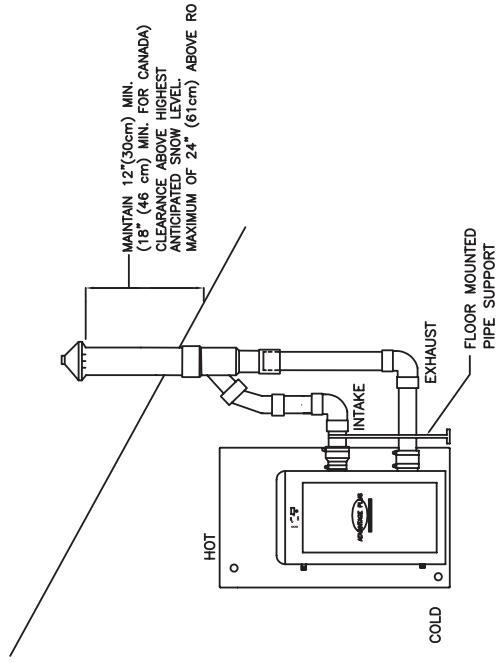

FIGURE 4
VERTICAL ROOF VENTING W/CONCENTRIC VENT KIT
(SP12161, 3 IN. - FRONT VIEW)

Note:

Spacing for multiple series of concentric vents should be the same as Multiple Vertical Vent in Fig. 3-3, P. 13.

PART 4: OPERATION

A. OVERALL APPLIANCE AND CONTROL OPERATION

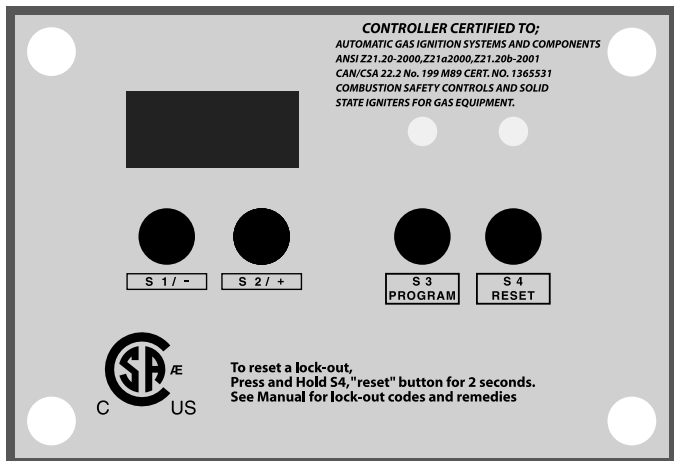

To adjust temperature of the stored water press and hold **S3** for 2 seconds. The first item is: **DU**: Water Temperature Set Point – factory set at 119°F, adjustable down by pressing **S1** key to 70°F and adjustable up by pressing the **S2** key up to 159°F. The **S3** key is then pressed again momentarily to display **DH**, the differential which is factory set at 7°F and adjustable down to 1°F by pressing the **S1** key and up to 18°F by pressing the **S2** key. The **S3** key is pressed again momentarily to display the choice of Fahrenheit “F” factory default or Celcius by pressing the **S1** key. When finished, press the **S3** key one final time to place unit back into operation. The control automatically re-starts if no key is pressed for 2 minutes.

B. STATUS MENU

Installers are also able to check the current status of the AdvantagePlus parameters by pressing **S4/RESET** key for 3 seconds. Once activated, the display will show **d1** alternating value of the actual upper supply tank temperature. Actual values are displayed for each function. To view the next value simply press the **S4** key to go to the next displayed value. Listed below are the values which can be displayed. These values cannot be changed. To exit this menu, simply press **S3/Program** key to resume normal operation.

Function Value

- d1 — Actual Temperature from upper tank sensor
- d2 — Actual Temperature from lower tank sensor
- d3 — **0** (Not used)
- d4 — **303** (Not used)
- d5 — **nc** (Not used)
- d6 — Actual Fan speed multiplied by 10 (Example: If fan speed displayed is **410** RPM x 10 = 4100 actual fan speed)

Function Value

- d7 — Actual Ionization current read from Flame Rectification probe
- d8 — **0** (Not used)
- d9 — **1** (Not used)
- d10 — Actual Status bus communication
co = connected, **nc** = not connected
- d11 — **32** (Not used)
- d12 — Power On Hours (Example:Hours x 1000
Ex. 0.1 = 100 hrs. or 1.0 = 1000 hrs.)
- d13 — Total Water Heating Hours (TW – Hrs. x 1000)
- d14 — **0** (Not used)
- d15 — Passed Ignition Attempts (Passed ignition x 1000)

FOR YOUR OWN SAFETY READ BEFORE OPERATING

1. This appliance does not have pilot. It is equipped with an ignition device which automatically lights the burner. Do not try to light the burner by hand.
2. BEFORE OPERATING smell all around the appliance area for gas. Be sure to smell next to the floor because some gas is heavier than air and will settle on the floor.

WHAT TO DO IF YOU SMELL GAS

- Do not try to light any appliance.
 - Do not touch any electric switch; do not use any phone in your building.
 - Immediately call your gas supplier from a neighbor’s phone. Follow the gas suppliers’ instructions.
 - If you cannot reach your gas supplier, call the fire department.
3. Turn on gas shutoff valve (located inside of the down near burner) so that the handle is aligned with the gas pipe. If the handle will not turn by hand, don’t try to repair it, call a qualified service technician. Force or attempted repair may result in a fire or explosion.
 4. Do not use this appliance if any part has been under water. Immediately call a qualified service technician to inspect the appliance and to replace any part of the control system and any gas control which has been under water.
 5. The AdvantagePlus shall be installed so the gas ignition system components are protected from water (dripping, spraying, rain, etc.) during appliance operation and service (circulator replacement, condensate trap, control replacement, etc.)

C. OPERATING INSTRUCTIONS

If you smell gas, **STOP**. Follow listed safety instructions above. If you do not smell gas, follow the next steps.

1. Turn on all electric power to appliance. Make sure tank is full with cold water and purge all piping. To assure adequate purging, open all hot water faucets.
2. Adjust the temperature setpoint of the appliance if desired. The factory default setting is 119° (48°C). If changes are necessary follow "Overall Appliance and Control Operation" in this section.
3. If the appliance fails to start, refer to the Troubleshooting section in the back of this manual.

⚠ WARNING

When this water heater is supplying general purpose hot water requirements for individuals, a thermostatically controlled mixing valve for reducing point of use water temperature is recommended. Contact a licensed plumber or the local plumbing authority for further instructions.

The three digit LED display will illustrate actual water temperature within the tank under normal operating conditions. However, this display is also used to indicate the temperature set point when in the programming mode.

The controller has a temperature set point range of 70°F (21°C) to 159°F (70.5°C) (Booster models have a maximum set point of 180°F [82°C]), with a factory setting of 120°F (49°C).

NOTE: Power must be applied to the controller prior

⚠ CAUTION

In unusually dirty or dusty conditions, care must be taken to keep appliance door in place. Failure to do so VOIDS WARRANTY!

to any programming operations.

The control system requires no periodic maintenance under normal conditions. However, in unusually dirty or dusty conditions, periodic vacuuming of the cover to maintain visibility of the display and indicators is recommended.

D. SHUTDOWN PROCEDURE

If the burner is operating, lower the set point value to 70°F (21°C) and wait for the burner to shut off. Continue to wait for the combustion blower to stop so all latent combustion gases are purged from the system. This should take a maximum of 40 to 90 seconds, then disconnect the electrical supply. If the burner is not operating, disconnect the electrical supply.

⚠ WARNING

Should overheating occur or the gas supply fail to shut off, turn off the manual gas control valve to the appliance.

⚠ WARNING

DO NOT use this appliance if any part has been under water. Immediately call a qualified service technician to inspect the appliance and to replace the water heater if the control system or any gas control which has been under water.

E. PREVENT COMBUSTION AIR CONTAMINATION

Install intake air piping for the AdvantagePlus Water Heater as described in the Venting section. Do not terminate exhaust in locations that can allow contamination of intake air.

⚠ WARNING

You must pipe outside air to the water heater air intake. Ensure that the intake air will not contain any of the contaminants below. Contaminated air will damage the water heater, resulting in possible severe personal injury, death or substantial property damage. For example, do not pipe intake air vent near a swimming pool. Also avoid areas subject to exhaust fumes from laundry facilities. These areas will always contain contaminants.

F. CORROSIVE CONTAMINANTS AND SOURCES

PRODUCTS TO AVOID

Spray cans containing fluorocarbons
Permanent wave solutions
Chlorinated waxes/cleaners
Chlorine-based swimming pool chemicals
Calcium chloride used for thawing
Sodium chloride used for water softening
Refrigerant leaks
Paint or varnish removers
Hydrochloric acid/muriatic acid
Cements and glues
Antistatic fabric softeners used in clothes dryers
Chlorine-type bleaches, detergents, and cleaning solvents found in household laundry rooms
Adhesives used to fasten building products and other similar products

AREAS LIKELY TO HAVE CONTAMINANTS
Dry cleaning/laundry areas and establishments
Swimming pools
Metal fabrication plants
Beauty shops
Refrigeration repair shops
Photo processing plants
Auto body shops
Plastic manufacturing plants
Furniture refinishing areas and establishments
New building construction
Remodeling areas
Garages and workshops

G. CONDENSATE

This is a condensing high efficiency appliance, therefore this unit has a condensate removal system. Condensate is nothing more than water vapor, derived from the combustion products, similar to an automobile when it is initially started. This condensate does have a low pH and should be treated with a condensate filter. This filter contains either lime crystals or marble crystals, which will neutralize the condensate. The outlet of the filter is sized for 5/8" (1.6 cm) ID (inside diameter) plastic tubing. It is very important that the condensate line is sloped away from and down to a suitable inside drain. If the condensate outlet on the AdvantagePlus is lower than the drain, you must use a condensate removal pump. It is also very important that the condensate line is not exposed to freezing temperatures, or any other type of blockage. Plastic tubing should be the only material used for the condensate line. Steel, brass, copper, or other metals will be subject to corrosion and deterioration. A second vent may be necessary to prevent condensate line vacuum lock if a long horizontal run is used. Also an increase to 1" (2.5 cm) tubing may be necessary.

NOTE: Always check local codes for proper evacuation of condensate.

⚠ DANGER
 Do not install the AdvantagePlus into a common vent with any other appliance. This will cause flue gas spillage or appliance malfunction, resulting in possible severe personal injury, death or substantial property damage.

INSTALLATION OF A CONDENSATE NEUTRALIZER AND PUMP (Not Supplied)

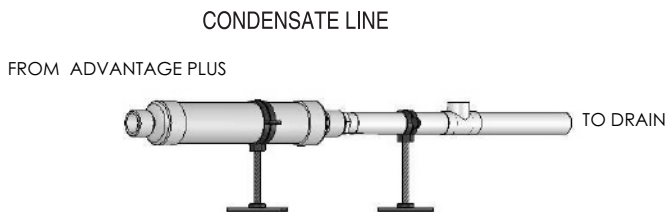

CONDENSATE LINE MUST BE PITCHED AT LEAST 1/4" (0.64 cm 0.3 m) PER FOOT TO PROPERLY DRAIN. IF THIS CANNOT BE DONE OR A VERY LONG LENGTH OF CONDENSATE HOSE IS USED YOU MUST INCREASE THE CONDENSATE HOSE TO A MINIMUM OF 1" (2.5 cm) I.D. AND PLACE A TEE IN THE LINE AFTER THE CONDENSATE NEUTRALIZER TO PROPERLY REDUCE VACUUM LOCK IN THE DRAIN LINE.

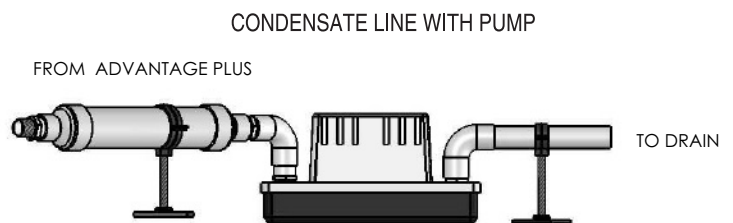

CONTACT YOUR LOCAL WHOLESALE PLUMBING SUPPLY STORE FOR MORE INFORMATION ON CONDENSATE NEUTRALIZERS AND PUMPS

Notes:

- CONDENSATE LINE MUST BE PITCHED AT LEAST 1/4" PER FOOT (0.64 cm per 0.3 m) TO PROPERLY DRAIN. IF THIS CANNOT BE DONE OR A VERY LONG LENGTH OF CONDENSATE HOSE IS USED YOU MUST INCREASE THE CONDENSATE LINE TO A MINIMUM OF 1" (2.5 CM) ID AND PLACE A TEE IN THE LINE AFTER THE CONDENSATE NEUTRALIZER TO PROPERLY REDUCE VACUUM LOCK IN THE DRAIN LINE.
- PLASTIC PIPE SHOULD BE THE ONLY MATERIAL USED FOR THE CONDENSATE LINE. STEEL, BRASS, COPPER OR OTHERS WILL BE SUBJECT TO CORROSION OR DETERIORATION.
- IT IS ALSO VERY IMPORTANT THAT THE CONDENSATE LINE IS NOT EXPOSED TO FREEZING TEMPERATURES, OR ANY OTHER TYPE OF BLOCKAGE.

PART 5: COMPONENTS OF THE ADVANTAGEPLUS

ITEM #	DESCRIPTION	REPLACEMENT PART #
1	GASKET - MOUNTING PLATE	SP15138
2	SPARK ELECTRODE - NATURAL (w/GASKET, SCREWS)	SP15128
	SPARK ELECTRODE - LP (w/GASKET, SCREWS)	SP15134
3	FLAME RECTIFICATION PROBE (w/GASKET, SCREWS)	SP15129
4	GASKET - BURNER/COMBUSTION BLOWER	SP15139
5	BURNER - 130k BTU and under (w/GASKET)	SP15126
	BURNER - 160k BTU and over (w/GASKET)	SP15127
6	GASKET - SIGHT GLASS	SP15152
7	SIGHT GLASS (w/2 GASKETS)	SP15136
8	COMBUSTION BLOWER (w/GASKET, ADAPTER PLATE, SCREWS)	SP15130
9	AIR INTAKE ADAPTER - BLOWER SIDE	SP15158
10	SWIRL PLATE - 130k BTU and under	SP15155
	SWIRL PLATE - 160k BTU and over	SP15156
11	AIR INTAKE ADAPTER - VALVE SIDE	SP15157
12	GAS VALVE - 130k BTU and under (w/AIR INTAKE ADAPTER, SWIRL PLATE, SCREWS)	SP15131
	GAS VALVE - 160k BTU and over (w/AIR INTAKE ADAPTER, SWIRL PLATE, SCREWS)	SP15132
13	BLOCKED VENT PRESSURE SWITCH	SP21140
14	OVER TEMPERATURE SWITCH	SP12149
15	2" FLEXIBLE HOSE - AIR INTAKE	SP15137
16	926 CONTROL BOARD - 160°F (71°C) - 100k BTU	SP15133D
	926 CONTROL BOARD - 160°F (71°C) - 130k BTU	SP15133A
	926 CONTROL BOARD - 160°F (71°C) - 160k BTU	SP15133B
	926 CONTROL BOARD - 160°F (71°C) - 199k BTU	SP15133C
	926 CONTROL BOARD - 180°F (82°C) - 160k BTU	SP15133E
	926 CONTROL BOARD - 180°F (82°C) - 199k BTU	SP15133F
17	926 DISPLAY BOARD (w/RIBBON CABLE)	SP15153
	LOW VOLTAGE WIRING HARNESS (ATTACHED TO CONTROL BOARD - NOT SHOWN)	SP15183
	120 Vac BLOWER WIRING HARNESS (ATTACHED TO CONTROL BOARD - NOT SHOWN)	SP15184
18	TEMPERATURE PROBE	SP12142
19	LOW WATER CUT-OFF SWITCH	SP15140

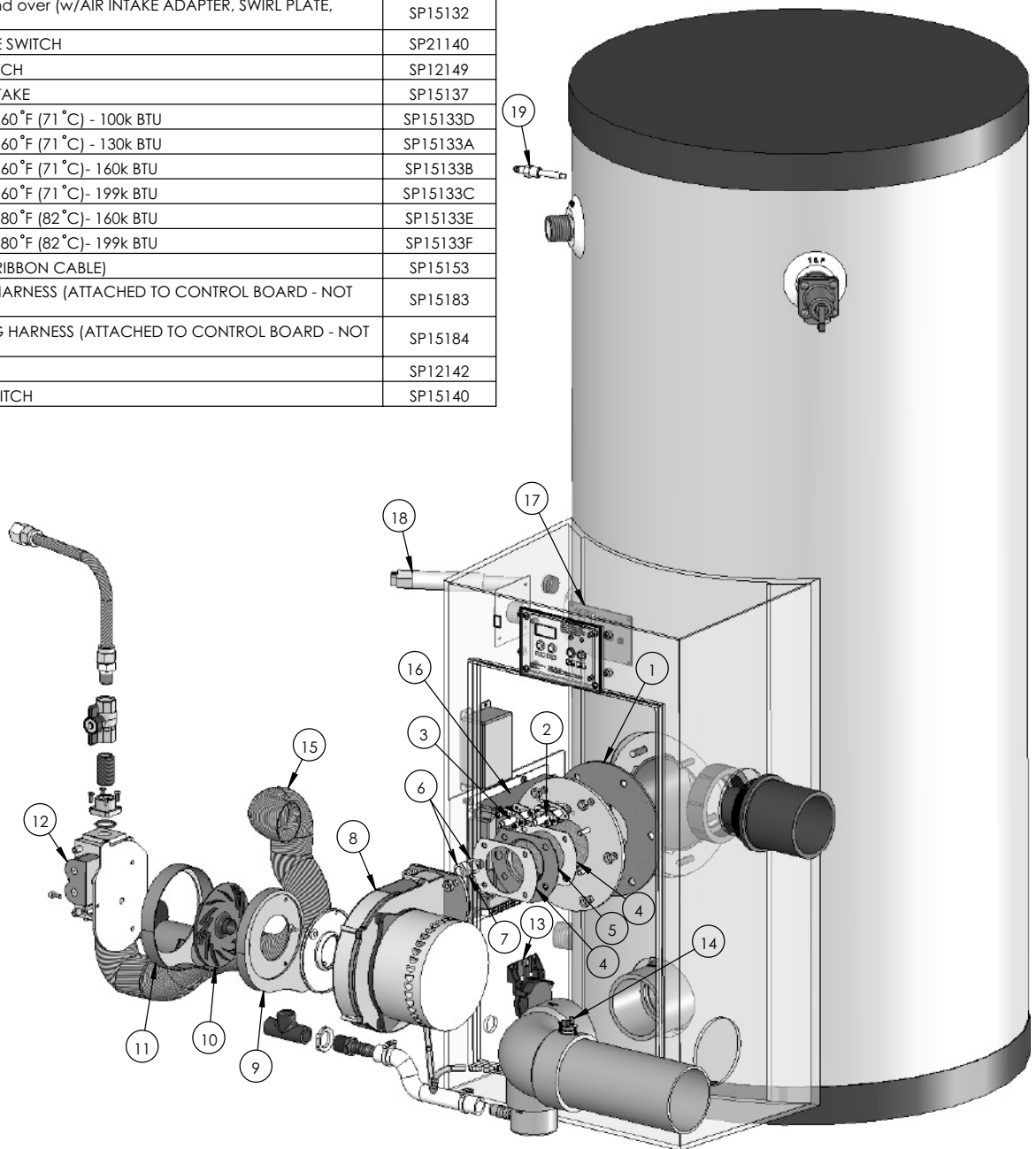

ADVANTAGE PLUS WIRING

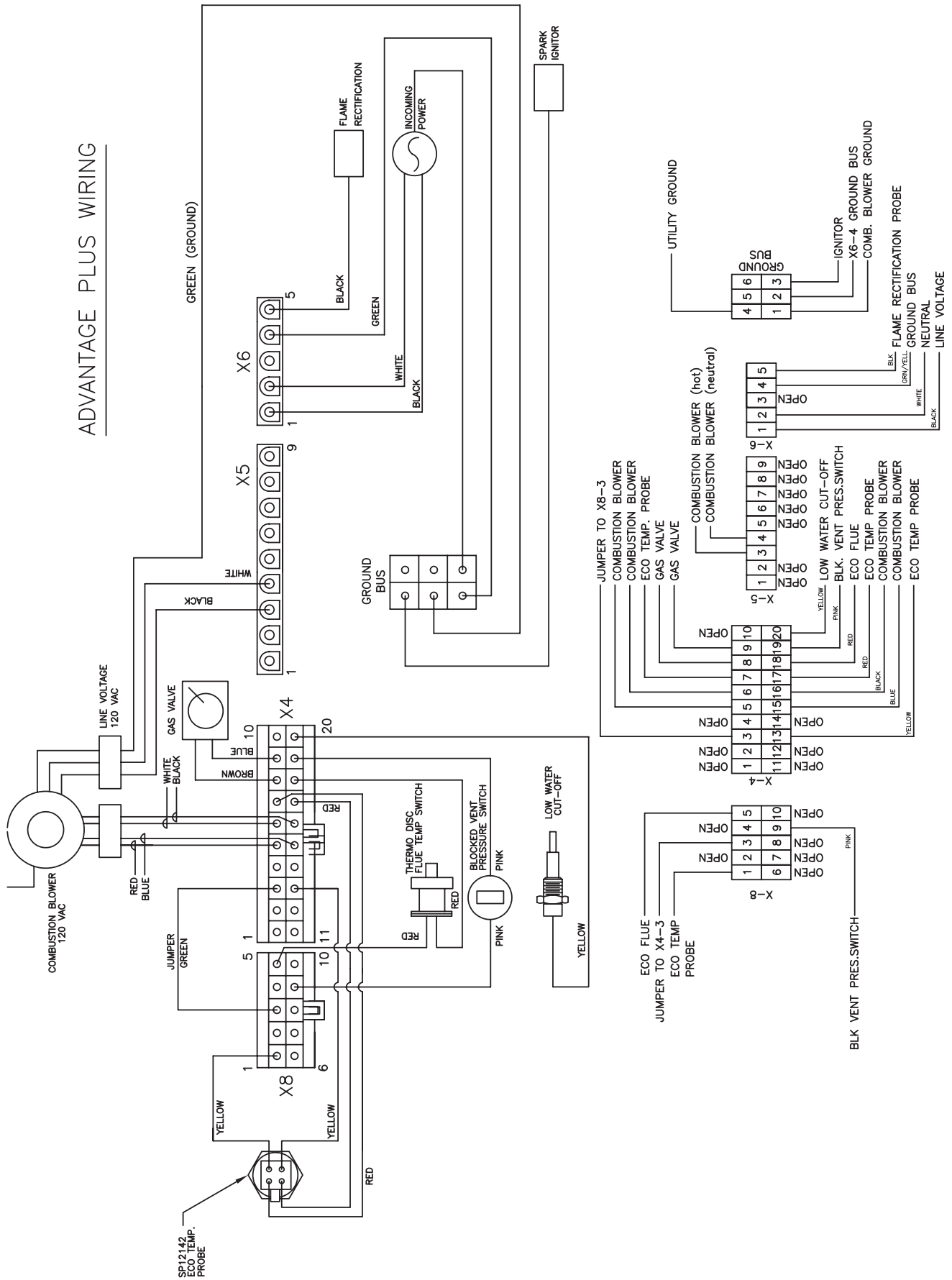

HOW TO OBTAIN SERVICE ASSISTANCE

Should you have any questions about your new water heater, or if it requires adjustment, or routine maintenance, it is suggested that you first contact your installer, plumbing contractor or previously agreed upon service agency. In the event that the firm has moved, or is unavailable, refer to the telephone directory commercial listings or local utility for qualified service assistance.

Should your problem not be resolved to your complete satisfaction, you should then contact the Manufacturer's National Service Department at the following address:

In the United States:

RHEEM MANUFACTURING COMPANY
1241 Carwood Ct.
Montgomery, AL 36117

In Canada:

Rheem Canada Ltd
125 Edgeware Road, Unit 1
Brampton, ON
L6Y 0P5

You may also obtain technical assistance by calling 1-800-432-8373.

When contacting the manufacturer, the following information should be made available:

1. Model and serial number of the water heater as shown on the rating plate attached to the jacket of the water heater.
2. Address where the water heater is located and can be seen.
3. Name and address of installer and any service agency who performed service on the water heater.
4. Date of original installation and dates any service work was performed.
5. Details of the problems as you can best describe them.
6. List of people, with dates, who have been contacted regarding your problem.

MOST COMMON ADVANTAGEPLUS INSTALLATION CONCERNS

VENTING:

VENT LENGTH TOO LONG - OVER 85' (26m)
VENTING NOT PITCHED PROPERLY - CONDENSATE BUILD UP IN VENT
EXHAUST GAS RE-CIRCULATION - VENT TERMINALS NOT USED, WRONG FITTINGS USED, SIGHT PROBLEMS
BUSH IN FRONT OF VENT TERMINAL
INSIDE CORNER OF BUILDING FOR VENT LOCATION
OVERHANG WITH VENT UNDERNEATH
COMPOUND ROOF PITCH, OR ABOVE ROOF FIRE WALL
ADDITIONAL FITTINGS INSTALLED INTO TERMINALS
VENT SIZED FROM 3" TO 4" BY USING BUSHINGS - INSTEAD OF REDUCING COUPLING OR REDUCING ELBOW
VENT CHANGED FROM 3" TO 4" - WITHOUT GOING REQUIRED 15' (4.6m) ON BOTH INTAKE AND EXHAUST
VENTING NOT CLEANED AND GLUED TOGETHER FOR PRESSURE TIGHT JOINTS
INTAKE AIR CONTAINING EXHAUST FROM ANOTHER VENT OR APPLIANCE

GAS SUPPLY:

GAS PRESSURE TOO LOW - NEED 3.5" WC (0.87 kPa) GAS PRESSURE UP TO 14" WC (3.5 kPa) GAS PRESSURE
GAS METER TOO LOW IN CAPACITY
GAS REGULATOR NOT SIZED PROPERLY - TOO LOW IN CAPACITY
GAS PIPE TOO SMALL - 3/4" MINIMUM GAS SUPPLY SIZE
GAS REGULATOR TOO CLOSE TO APPLIANCE - NEED 10' OF PIPE FOR EVERY 200,000 BTU'S PER HOUR
GAS REGULATOR WITH LONG VENT OR BLEED VENT ORIFICE - REGULATOR SLOW TO RESPOND
GAS METER RESTRICTION, OR IN NEED OF REPAIR/REPLACEMENT
GAS SUPPLY PRESSURE DROPS BELOW 3.5" WC (0.87 kPa) WHEN APPLIANCE FIRES

ELECTRICAL:

APPLIANCE NOT GROUNDED
ELECTRICAL POLARITY REVERSED - FLAME WILL LIGHT BUT GO BACK OUT IN 4-6 SECONDS VOLTAGE TOO LOW OR TOO HIGH
APPLIANCE CYCLES, BUT NO IGNITION - REMOVE ANY CORROSION FROM SPARK ELECTRODE AND RECTIFIER. CHECK GAP
SPACING ON SPARK ELECTRODE. SHOULD BE 1/4" SPACING.

PLUMBING: DIELECTRIC UNIONS INSTALLED - RUSTY WATER

CONDENSATE:

CONDENSATE LINE NOT PITCHED TO DRAIN
CONDENSATE LINE NOT DRAINING DUE TO LONG RUN WITHOUT VENT
CONDENSATE PUMP NOT WORKING
CONDENSATE TRAP PLUGGED

BURNER:

EXTREMELY LOUD BANG ON IGNITION - BURNER FAILED OR END CAP OFF
RED BURNER DECK AS SEEN THROUGH VIEW PORT - GAS VALVE NEEDS ADJUSTMENT

GAS VALVE:

PUFFING ON IGNITION - ADJUST GAS VALVE
LOUD POP ON IGNITION, THEN RUNNING SMOOTH - ADJUST GAS VALVE
HUFF AND PUFF DURING OPERATION - ADJUST GAS VALVE
RUNNING GREAT BUT INTERMITTENTLY HUFFING OR POPPING - CHECK FOR RE-CIRCULATION UNDER VENTING
IT IS IMPORTANT TO NOTE FOR MAINTENANCE PURPOSES: THE THREAD ON THE END OF THIS GAS VALVE AND NIPPLE IS A
LEFT HAND THREAD.

SEALING ADVANTAGEPLUS AS PER N.S.F. STANDARD NUMBER 5

TO SEAL THE BASE OF BOOSTER TO THE FLOOR TO
PREVENT SEE PAGE UNDERNEATH, PER N.S.F.
STANDARD #5 - APPLY A 3/8" BEAD OF RTV SILICONE
(AS SHOWN HERE), COMPLETELY AROUND TANK.

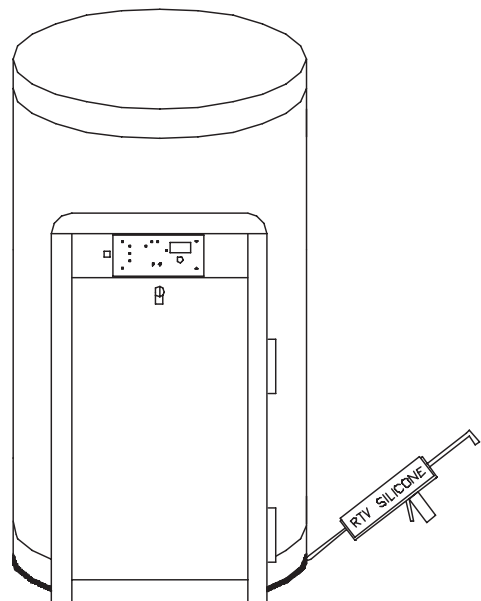

PART 6: TROUBLESHOOTING

Table 6-1: 926 Control Board Error Codes

Code	Description	Remedy
F00	High temperature switch limit exceeded (194°F [90°C])	<ol style="list-style-type: none"> 1. Try reset, if F00 repeats, create a demand for hot water (▲ DANGER: use caution to prevent burn injury) If water is above 194°F (90°C) test upper and lower temperature sensor with an ohmmeter. (Refer to resistance chart, this section.) Replace bad sensor. If water is below 194° (90°C) test high temperature switch and wiring with ohmmeter. Switch should be closed at this point, if not, replace switch. 2. If unit did reset successfully, let the unit run and go into the status menu to check the upper and lower temperature sensor. If either reading displayed does not make sense, check appropriate sensor with ohmmeter. (Refer to resistance chart this section.) Replace bad sensor. Do an OHMS reading on both sensors to check continuity.
F01	Vent temperature limit exceeded	<ol style="list-style-type: none"> 1. Inspect all flue piping. If the flue is damaged or shows signs of overheating then repair or replace the flue parts as necessary before proceeding. 2. If the flue piping system is intact, not damaged and there is no sign of the flue overheating such as discoloration or melting, then push the red reset button on the flue switch. 3. Be sure the unit is connected to a water supply and full of water. 4. Push the RESET button on the unit control panel. The appliance should light. If the appliance lights proceed to step 5. If the appliance does not light and the display again begins to flash F01, inspect the wiring to the flue switch, repairing or replacing as necessary. If the wiring is intact, replace the flue switch using care to mount the new flue switch in the same position and mounting holes as the old one. If the display flashes a code other than F01, follow the troubleshooting guide for that code. 5. Observe operation for 5 minutes. Place the probe of an exhaust analyzer into the flue system within 2 feet of the unit appliance. The exhaust temperature should not rise above 190°F (88°C) after several minutes of operation. 6. If the flue temperature is below 190°F (88°C) and the appliance again goes into lockout displaying F01, replace the flue switch using care to mount the new flue switch in the same position and mounting holes as the old one. If the display flashes a code other than F01, follow the troubleshooting guide for that code. 7. If the flue temperature increases to over 190°F (88°C), Consult the AdvantagePlus factory for further assistance.
F02	Interrupted or shorted upper temperature sensor	Check the electrical connection to the appropriate temperature sensor, if connection is okay, replace bad sensor.
F03	Interrupted or shorted lower temperature sensor	
F05	Upper temperature sensor exceeds 194°F (90°C)	If water in tank is not greater than 190°F (88°C), check wiring and repair if faulty. If the wiring is okay, check appropriate sensor with ohmmeter and compare to reading in resistance chart. If reading does not agree with water temperature, replace bad sensor.
F06	Lower temperature sensor exceeds 194°F (90°C)	
F09	No flame detected – The unit will make three attempts at ignition before the control goes into this lockout condition. Will reset in 1 hour.	<ol style="list-style-type: none"> 1. Watch the igniter through the observation window provided. 2. Make sure spark electrode cable is attached and intact 3. Remove any corrosion from the spark electrode and flame rectifier probe connections 4. If there is a spark but no flame, check the gas supply to the water heater. 5. If there is a flame, check the wiring connected to the flame rectifier probe to be sure it is intact. Remove the flame rectifier probe, inspect to be sure the insulator is not cracked, and clean any buildup off the probe. Reinstall the probe. 6. Check any flue blockage or condensate blocks.
F10	Loss of Flame Signal – The unit will relight 4 times before the control goes into this lockout condition. Will reset in 1 hour.	<ol style="list-style-type: none"> 1. Monitor gas line pressure while unit is running at high fire. Gas pressure must remain above 3.5 “WC during operation at high fire. If the pressure is low or becomes low during tank operation, inspect the gas piping and/or regulators for restrictions or freeze up. 2. If green light on display is not lit or is lit but goes out when the unit has flame, check the flame rectification probe wiring, insulator, and clean the flame rectifier probe as described under F09 above. 3. Check the flame signal on the status menu. If it is lower than 1.2 after cleaning the flame rectifier probe as described in step 2, replace the flame rectifier probe 4. If the green light doesn’t come on or goes off during operation check the flame signal on the status menu. 5. If the signal reads less than 1 microampere, clean the flame rectifier probe. 6. If the flame rectifier probe continues to read low, replace it.
F11	False Flame Signal – The water heater will lock out if it senses a flame signal when there should be none present.	<ol style="list-style-type: none"> 1. Turn the gas off to the unit at the service valve. 2. If the flame signal is still present replace the igniter. 3. If the flame signal is not present after turning off the gas supply, check the gas valve electrical connection. 4. If there is no power to the gas valve, remove the valve and check for obstruction in the valve seat or replace the gas valve. 5. Turn the gas on at the service valve after corrective action is taken.
F13	Combustion Fan Speed Incorrect – The water heater will lock out if it senses that the fan speed is less than 70% of expected rate for more than 60 seconds.	<ol style="list-style-type: none"> 1. Check the combustion air fan wiring. 2. Replace the combustion air fan. 3. Replace the control board.

NOTE: IF YOU REPLACE A PART TO REMEDY A FAULT, IT IS RECOMMENDED THAT YOU CYCLE THE UNIT AT LEAST THREE OR FOUR TIMES TO ASSURE THE FAULT HAS BEEN RESOLVED.

Table 6-2: AdvantagePlus Resistance Table for Supply Temperature Sensor

High/Low Temp. Sensor Temp.	Resistance (ohms)
32°F (0°C)	32550
41°F (5°C)	25340
50°F (10°C)	19870
59°F (15°C)	15700
68°F (20°C)	12490
77°F (25°C)	10000
86°F (30°C)	8059
95°F (35°C)	6535
104°F (40°C)	5330
113°F (45°C)	4372
122°F (50°C)	3605
131°F (55°C)	2989
140°F (60°C)	2490
149°F (65°C)	2084
158°F (70°C)	1753
167°F (75°C)	1481
176°F (80°C)	1256
185°F (85°C)	1070
194°F (90°C)	915
202°F (95°C)	786
212°F (100°C)	667

Table 6-3: 926 Control Board Error Codes

Code	Description	Duration	Corrective Action
E13	Combustion Fan Speed Low. The combustion air fan speed less than 70% of expected.	60 Sec.	<ol style="list-style-type: none"> 1. Check the combustion air fan wiring. 2. Replace the combustion air fan. 3. Replace the control board.
E14	Combustion Fan Speed High. The combustion air fan speed is more than 130% of expected.	60 Sec.	<ol style="list-style-type: none"> 1. Check the combustion air fan wiring. 2. Replace the combustion air fan. 3. Replace the control board.
LEO	Water level in tank is low	Until Corrected	<ol style="list-style-type: none"> 1. Be sure all air is bled from system. 2. Inspect low level switch and wiring for damage and repair as necessary.
FLU	Blocked Vent Pressure Switch Open	Until Corrected	<ol style="list-style-type: none"> 1. Assure that the vent is not blocked 2. Check the blocked vent pressure switch operation by applying a jumper. (If the switch is not functioning properly, replace it.)
LOU	24 VAC low	Until Corrected	<ol style="list-style-type: none"> 1. Check line voltage. Must be between 100-128 VAC. 2. If available, connect PC and using AdvantagePlus service software. Check the 24 VAC supply display in the lower left corner of the screen. The number displayed here must be greater than 128 and should be greater than 250. Use this as a troubleshooting guide as you follow the steps below. 3. Turn off power to the unit. Remove the 20 pin and 10 pin connectors from the control board. Reapply power to the unit. 4. If the LOU code is still present go to Step 5. If the LOU code is not present, the wiring harness or a sensor is shorted to ground. Check each sensor for shorts to ground and replace the faulty sensor. If all are good, repair or replace the wire harness. 5. If the LOU code is still present, the control board must be replaced. Note that there will be another code present with these connectors disconnected. This is normal. 6. If LOU only occurs when the burner tries to light, check the gas valve for excessive current draw.

